

# Automotive ESD Protection

AEC-Q101 Qualified ESD Devices for Network Transceivers

**AEC-Q101 Qualified**



## ► Key Features

- Bi-directional high ESD robustness up to 30kV
- Excellent ESD clamping behavior
- Low device capacitance
- Package miniaturization
- AEC-Q101 qualified

## ► Target Applications

- ECU
- Lighting control
- Passenger seat module
- Instrument panel



## ► Compliant with ISO 10605

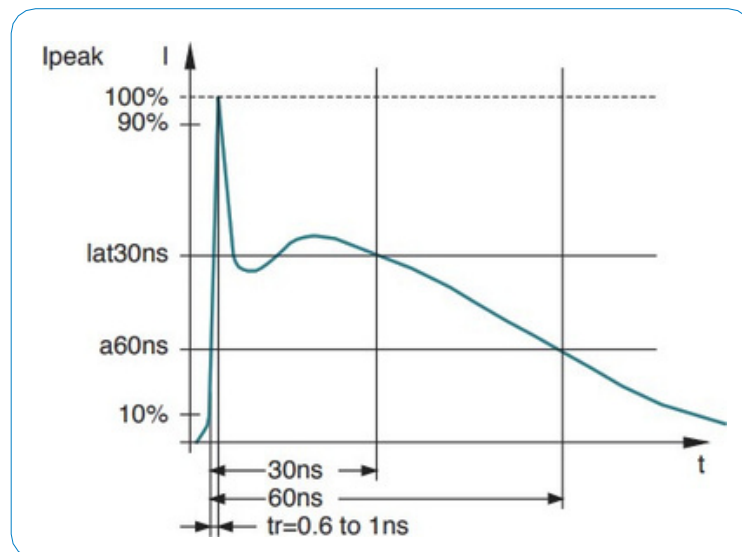

## ➤ Capacitance matches 20 Kbit/s – 10 Mbit/s

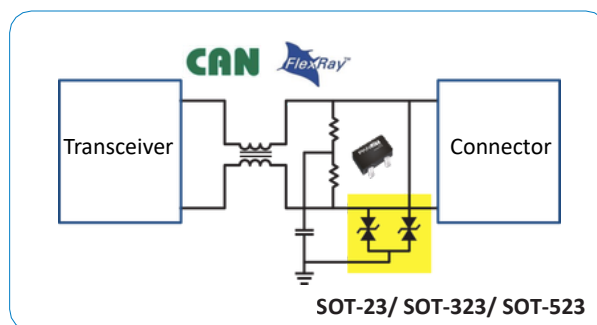
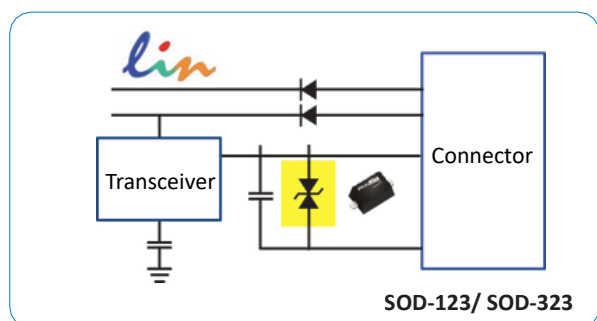
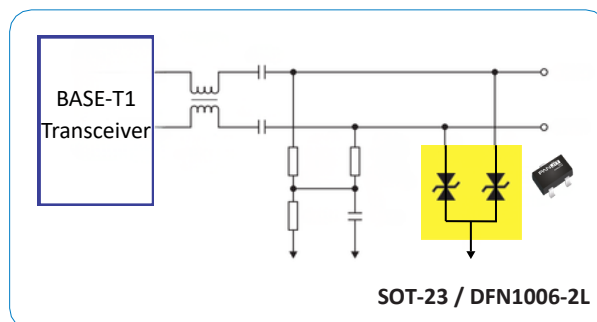
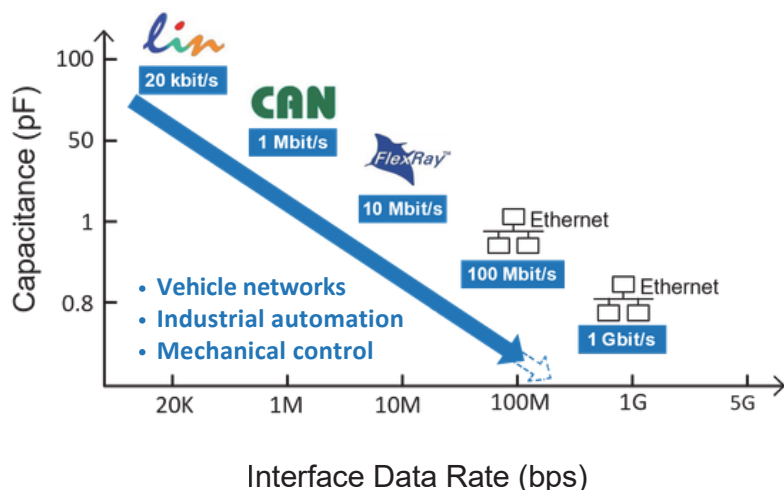

## ➤ Products

Application	Power System	Channel	$V_{RWM}$	Part Number	Package
	V		V		
LIN BUS	12 / 24	1	24	PEC3824AS-AU	SOD-123
		1	24	PEC3824CS-AU	SOD-323
CAN BUS	12	2	24	PEC3824C2A-AU	SOT-23
		2	24	PEC3824C2C-AU	SOT-323
		2	24	PEC3824C2E-AU	SOT-523
	24	2	36	PEC3836C2A-AU	SOT-23
		2	36	PEC3836C2C-AU	SOT-323
		2	36	PEC3836C2E-AU	SOT-523
	48	2	48	PEC3848C2A-AU	SOT-23
		2	54	PEC3854C2A-AU	SOT-23
2	72	PEC3872C2A-AU	SOT-23		
Ethernet	12 / 24	2	24	PEC22SD24C2A-AU	SOT-23
		1	24	PEC22SD24M1Q-AU	DFN1006-2L
	48	2	48	PEC22SD48C2A-AU	SOT-23
		2	60	PEC22SD60C2A-AU	SOT-23
		1	48	PEC22SD48M1Q-AU	DFN1006-2L
		1	60	PEC22SD60M1Q-AU	DFN1006-2L